

# PILOTINO WiFi™ PCB

Instruction Manual

# INDEX

<b>1. Introduction</b>	Pg. 3
<b>2. Safety Information</b>	Pg. 4
<b>3. Specification Characteristics</b>	Pg. 4
<b>4. Onboard Features (Nomenclature)</b>	Pg. 5
<b>5. Mechanical Details</b>	Pg. 6
<b>6. Installation</b>	Pg. 7
<b>6.1 Access Point Mode Installation</b>	Pg. 8
<b>6.1.1 Basic Connection</b>	Pg. 8
<b>6.1.2 Daisy Chain</b>	Pg. 9
<b>6.2 Station Mode Installation</b>	Pg. 10
<b>6.2.1 Basic Connection</b>	Pg. 10
<b>6.2.2 Daisy Chain</b>	Pg. 11
<b>6.3 Stand Alone Mode Installation</b>	Pg. 12
<b>6.3.1 Basic Connection (Access point)</b>	Pg. 12
<b>6.3.2 Daisy Chain (Access point)</b>	Pg. 13
<b>6.3.3 Basic Connection (Station)</b>	Pg. 14
<b>6.3.4 Daisy Chain (Station)</b>	Pg. 15
<b>7. WiFi - Access point Mode</b>	Pg. 16
<b>7.1 Basic Connection</b>	Pg. 16
<b>7.2 Art-Net App Connection</b>	Pg. 16
<b>8. WiFi - Station Mode</b>	Pg. 17
<b>8.1 Network Connection (WPS)</b>	Pg. 17
<b>8.2 IP address</b>	Pg. 18
<b>8.3 Art-Net App connection</b>	Pg. 18
<b>9. Default Setting</b>	Pg. 19
<b>10. Mode LED Indicator</b>	Pg. 19
<b>11. Hardware and Accessories</b>	Pg. 20
<b>UL Certification</b>	Pg. 21

# 1. Introduction

The PILOTINO WiFi™ PCB is the newest addition to the LED CV DMX decoder family for SIRS-E®. This version of the PILOTINO™ comes in a bare PCB format. This product is intended to be embedded into custom fixtures and lighting control systems in which component size is critical. Equipped with four mounting holes, the PILOTINO WiFi™ PCB is ready to be installed with M2.5 X 5mm stand-offs into any sort of enclosure.

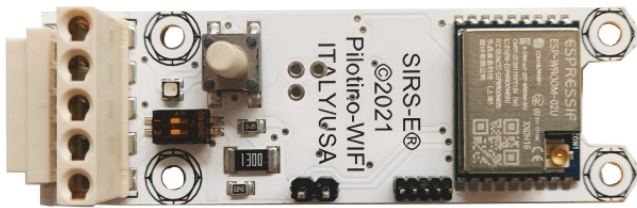

PILOTINO WiFi™ PCB

## Key Features: PILOTINO WiFi™ PCB

- Compatible with any ArtNet App
- Robust Wireless 2.4GHz Signal
- Standalone WiFi Network
- Onboard IO socket for quick integration
- Wire to Board Quick Connectors
- Plug and Play with Onboard IO Socket
- Made in Italy with 5 Year Warranty

One of the most important features of this product involves the onboard IO socket. This socket is meant to be used with the PILOTINO™ PCB with onboard WiFi or capabilities. With the WiFi module, you instantly convert this PILOTINO™ PCB into an ArtNet node receiving unit. Allowing for a completely wireless solution.

## 2. Safety Information

### Safety Information

The exposed PCB design of this product results in a major reduction in its foot print. With a slim and narrow design, this configuration is intended to be used in applications that would benefit from this feature. Some examples of applications include: fixture integration, custom control enclosures, and others. The exposed design comes with few precautions to take notice of.

The PILOTINO WiFi™ PCB is a non-waterproof device with an IP 20 rating. Keep the unit dry at all times and away from liquids and humid environments. Make all connections to the power supply, the DMX line and the antenna prior to powering on the circuit. All lead voltage connections to the drivers must be performed by a licensed electrician. Do not touch any of the surfaces of the device once the unit is powered on. Ensure that all connections are secure and eliminate all possibilities of shorting the unit. Use the proper wire gauge for the wire to board connections. We recommend using 18 awg stranded wire for the power input, and the DMX daisy chain connection. Do not mount the unit where vibrations or shock are present.

## 3. Specification Characteristics

### Hardware Specifications

Working Voltage: 5V DC
Operating current: 80 mA
Min current from supply: 500 mA
Operating temperature: -10 °C to 45 °C
Frequency: 2.4 GHz - 2.5 GHz
Antenna connector: u.FL
Working Humidity: 0% - 90% non-condensing
IP Rating: IP 20 Non-waterproof (Keep dry)
Ventilation: Do not install in airtight spaces

### Software Specification

WiFi mode: Station/SoftAP
Security: WPA/WPA2
Encryption: WEP/TKIP/AES

## 4. Onboard Features

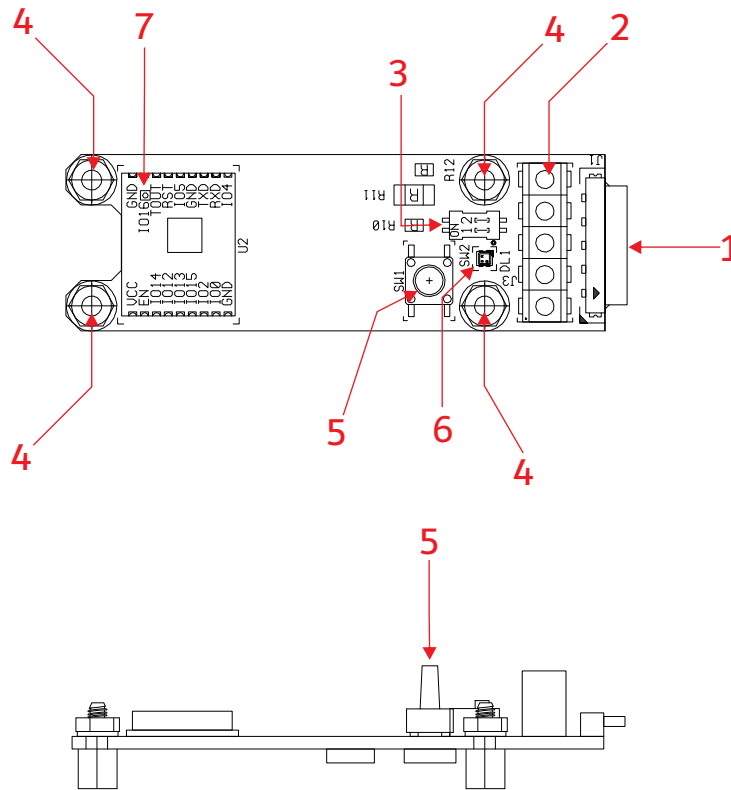

1. I/O Connection Socket + DMX out (For PILOTINO™ PCB)
2. I/O wire to board quick connectors
3. Dip Switches to set the DMX line termination
4. Mounting holes for Standoffs M2.5 (metric)
5. Pairing button for WiFi connections
6. Mode Indicator LED
7. u.FL connector to connect a receiving Antenna

## 5. Mechanical Details

PILOTINO WiFi™ PCB Top View

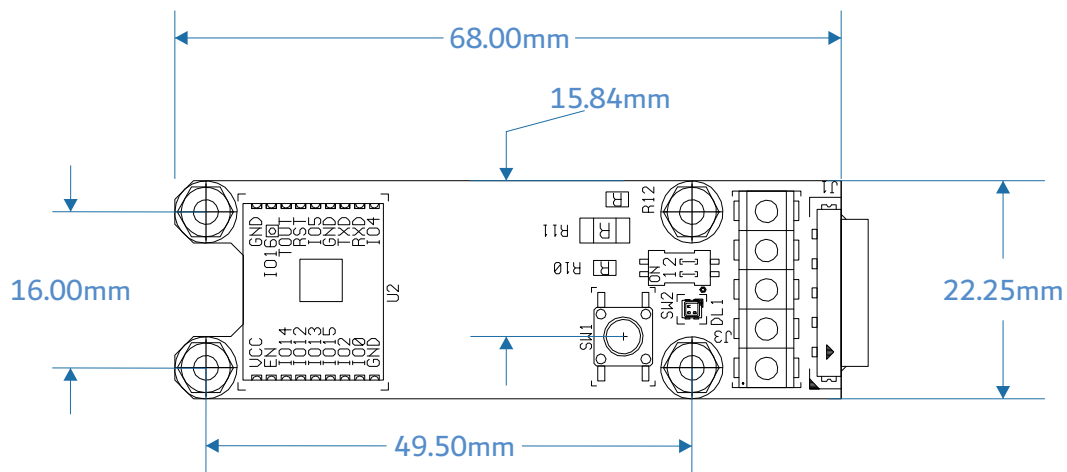

PILOTINO WiFi™ PCB Side View

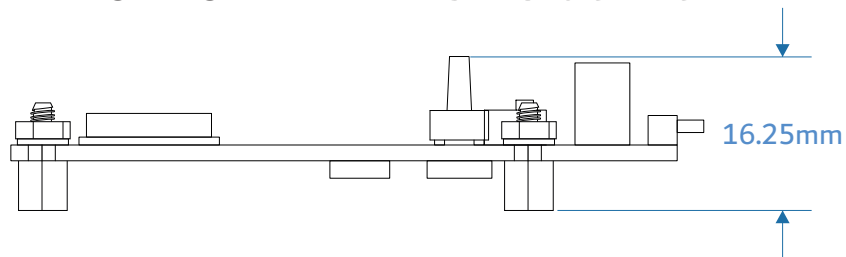

## 6. Installation

### Standoffs

Four 2.5M x 5mm standoffs should be used to properly mount the unit onto a smooth and level surface. It is recommended that the included factory 2.5M stand offs be used. To fasten the PILOTINO WiFi™ PCB onto a surface, first screw the four screws in a crisscross pattern. To tighten the screws, torqued them down to ¼ turn past hand tight, again in a crisscross pattern. Always tighten the screw opposite to the last screw that was torqued down. Do not over tighten the screws as doing so will result in damage to the device.

### Clearance

Due to the exposed contact points on the PILOTINO WiFi™ PCB, the risk of shorting the unit should be considered. A minimum of 10mm of clearance space is recommended. Never install the PILOTINO WiFi™ PCB within an enclosed space in which the PILOTINO WiFi™ PCB does not have sufficient space away from other components.

### Connections

The PILOTINO WiFi™ PCB comes equipped with wire to board quick connectors, and a socket connector to connect to the PILOTINO™ PCB . Properly connect the PILOTINO WiFi™ PCB to the PILOTINO™ PCB with the boards facing the same direction. All wire connections should fit securely into the connectors. Be sure to insert each wire into the connectors deep enough so that no bare wire is exposed. A good rule of thumb is to strip the wires so that only about 3mm of insulation is removed.

To have the best network connection, place the PILOTINO WiFi™ PCB in a location where the antenna has a clear line of sight from the device connected to.

# 6.1 Access Point Mode Installation

## 6.1.1 Basic Connection

Make sure the PILOTINO WiFi™ PCB and antenna are connected to the PILOTINO™ PCB.

Power on the PILOTINO™ PCB board once proper wiring connections are done to eliminate short circuiting the board.

With the smartphone device, go to the “Settings -> WiFi/Network -> PilotWiFi\_####”, where #### is a random sequence of four numbers.

When first prompted for a password, type PilotWiFi\_0000.

Use any Art-Net IOS or Android App to drive the PILOTINO™ PCB.

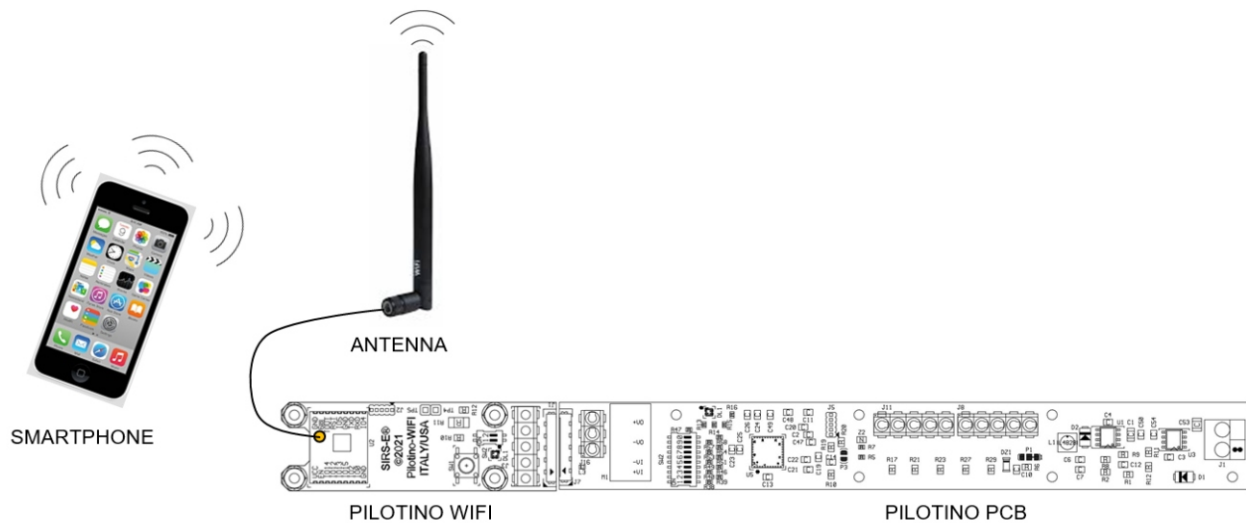



# 6.1 Access Point Mode Installation

## 6.1.2 Daisy Chain

Make sure the PILOTINO WiFi™ PCB and antenna are connected to the PILOTINO™ PCB.

Connect the DMX IN/OUT wires to each of the PILOTINO™ PCB boards in a sequence, similar to a daisy flower ring, to each corresponding connector.

Power on the PILOTINO™ PCB boards once proper wiring connections are done to eliminate short circuiting the boards.

With the smartphone device, go to the “Settings -> WiFi/Network -> PilotWiFi\_####”, where #### is a random sequence of four numbers.

When first prompted for a password, type PilotWiFi\_0000.

Use any Art-Net iOS or Android App to drive the PILOTINO™ PCB.

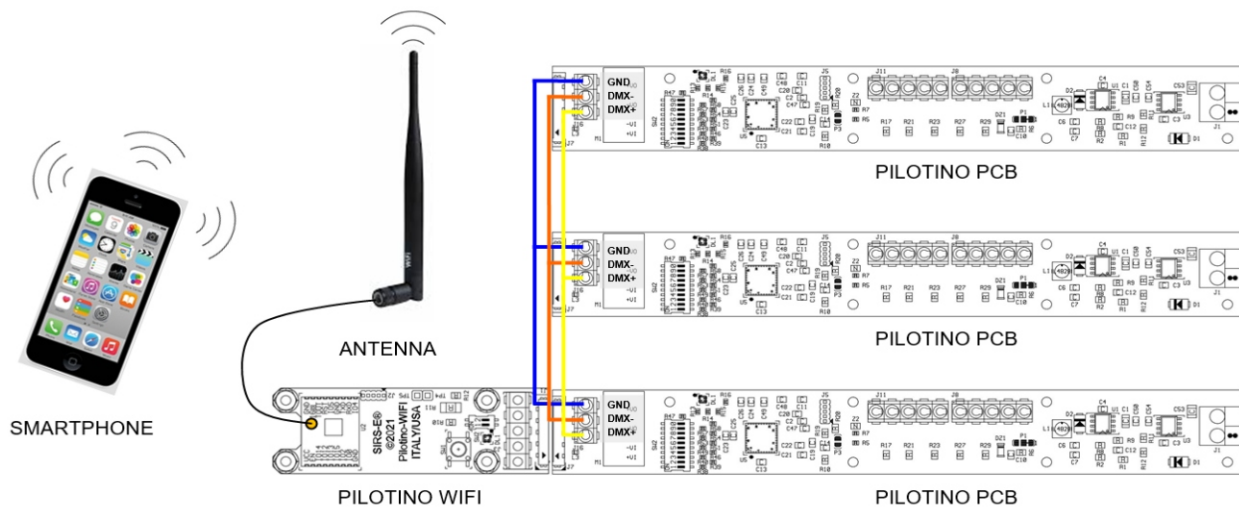

## 6.2 Station Mode Installation

### 6.2.1 Basic Connection

Make sure when connecting each PILOTINO WiFi™ PCB and antenna to a PILOTINO™ PCB. Power on the PILOTINO™ PCB boards once proper wiring connections are done to eliminate short circuiting the boards.

Connect the PILOTINO WiFi™ PCB to a router by a WPS procedure (for more details see chapter 8.1). Also, connect the smartphone to the router and use any Art-Net iOS or Android App to drive each PILOTINO™ PCB.

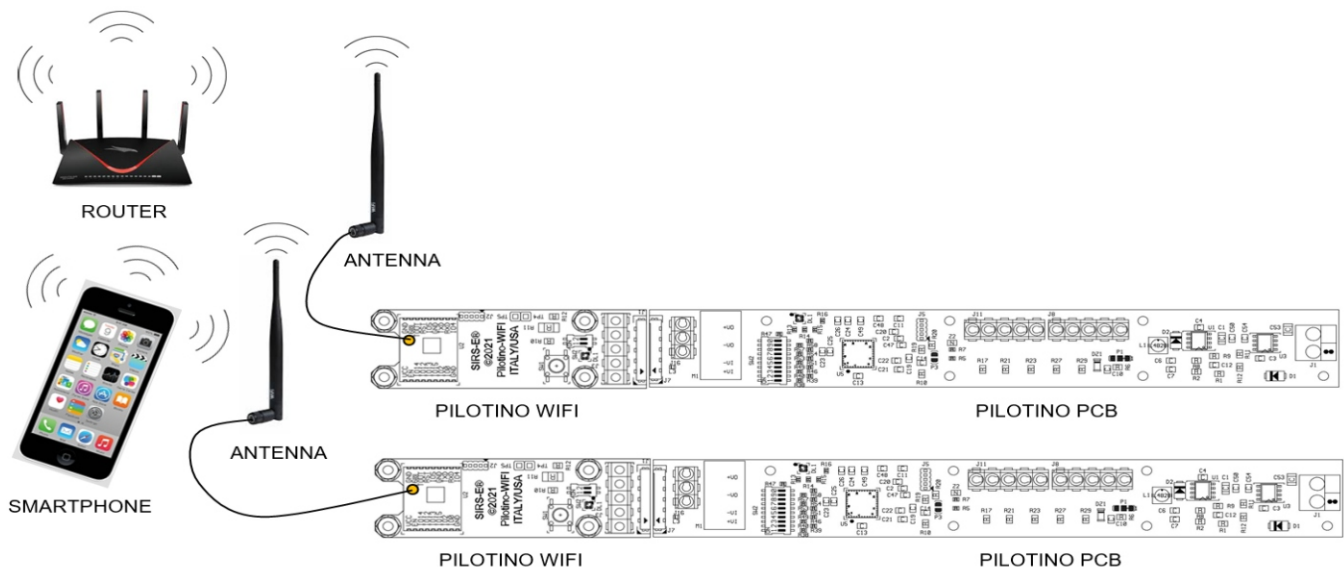

## 6.2 Station Mode Installation (cont.)

### 6.2.2 Daisy Chain

Make sure the PILOTINO WiFi™ PCB and antenna are connected to the PILOTINO™ PCB that is used individually and another PILOTINO™ PCB that is being daisy chained.

Connect the DMX IN/OUT wires to each of the PILOTINO™ PCB boards in a sequence, similar to a daisy flower ring, to each corresponding connector that are being daisy chained.

Power on the PILOTINO™ PCB boards once proper wiring connections are done to eliminate short circuiting the boards.

Connect the PILOTINO WiFi™ PCB to a router by a WPS procedure (for more details see chapter 8.1).

Also connect the smartphone to the router and use any Art-Net iOS or Android App to drive each PILOTINO™ PCB.

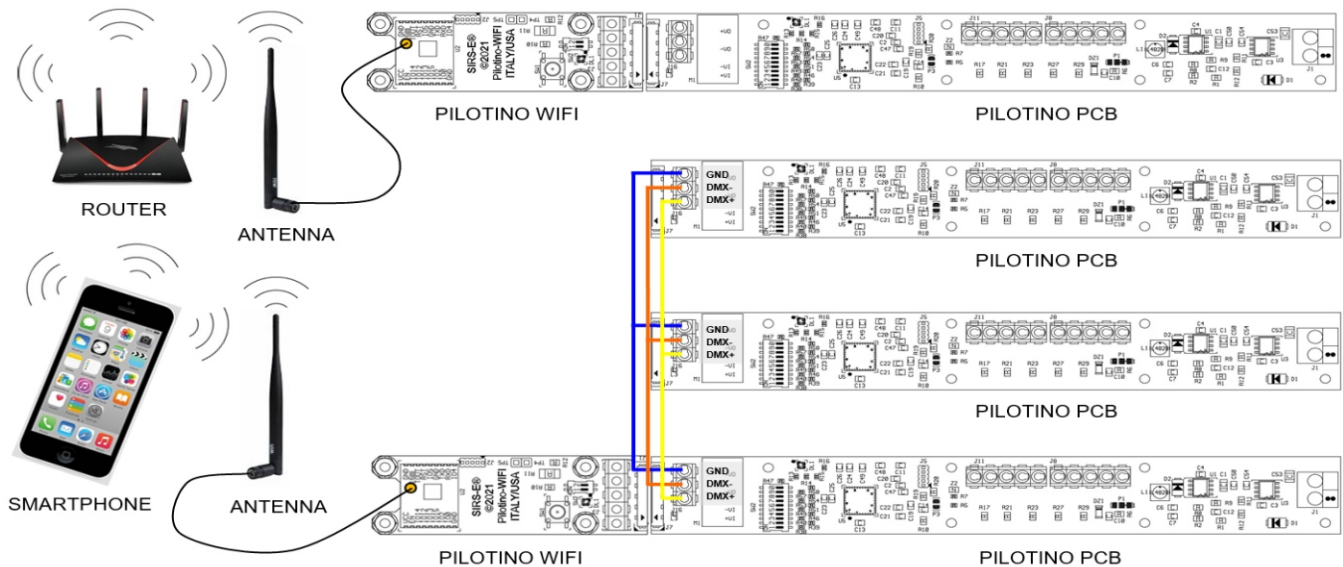

## 6.3 Stand Alone Mode Installation

### 6.3.1 Basic Connection (Access Point)

Make sure the PILOTINO WiFi™ PCB and antenna are connected to a power source (5 Vdc).

Properly connect the PILOTINO WiFi™ PCB to a DMX Driver utilizing the DMX IN/OUT connectors.

Power on the PILOTINO WiFi™ PCB once proper wiring connections are done to eliminate short circuiting the boards or controller.

With the smartphone device, go to the “Settings -> WiFi/Network -> PilotWiFi\_####, where #### is a random sequence of four numbers.

When first prompted for a password, type PilotWiFi\_0000.

Use any Art-Net iOS or Android App to drive the DMX device.

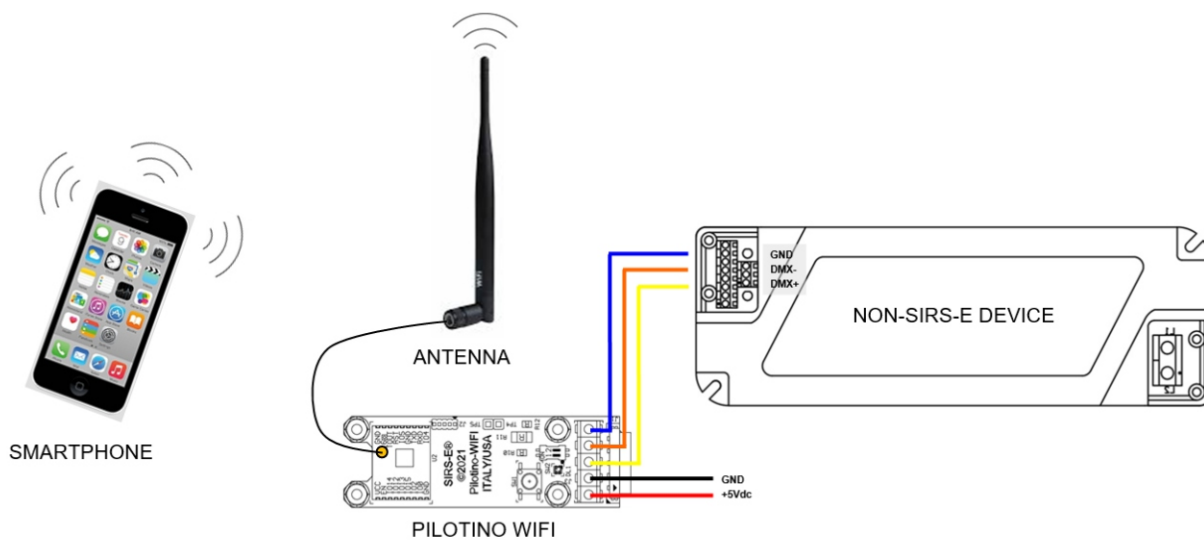

## 6.3 Stand Alone Mode Installation (cont.)

### 6.3.2 Daisy Chain (Access Point)

Make sure the PILOTINO WiFi™ PCB and antenna are connected to a power source (5 Vdc).

Connect the DMX IN/OUT wires to each of the DMX Drivers in a sequence, similar to a daisy flower ring, to each corresponding connector.

Power on the PILOTINO WiFi™ PCB once proper wiring connections are done to eliminate short circuiting the boards or controllers.

With the smartphone device, go to the “Settings -> WiFi/Network -> PilotWiFi\_####, where #### is a random sequence of four numbers.

When first prompted for a password, type PilotWiFi\_0000.

Use any Art-Net iOS or Android App to drive the DMX devices.

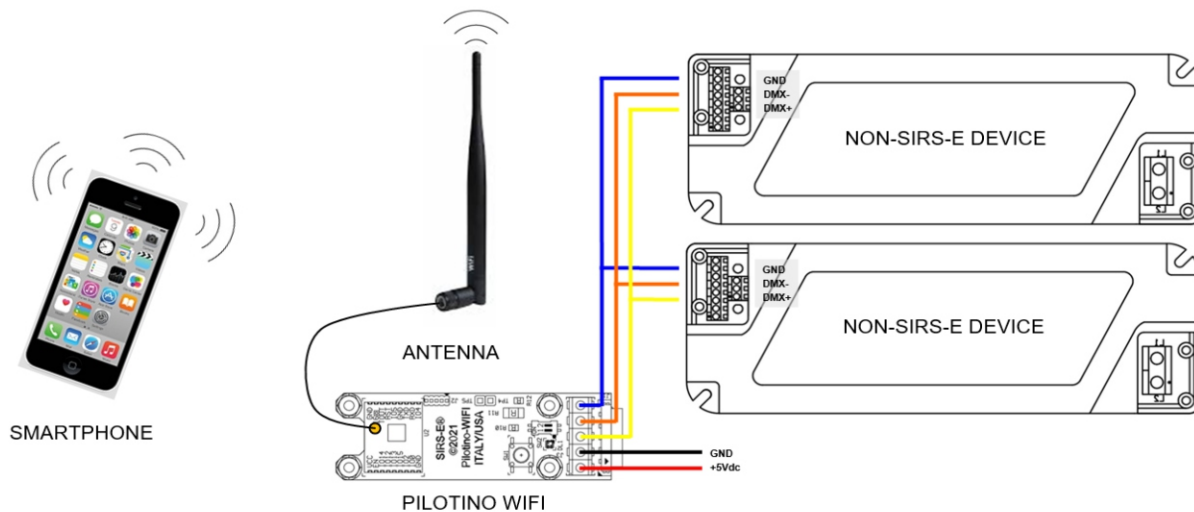

## 6.3 Stand Alone Mode Installation (cont.)

### 6.3.3 Basic Connection (Station)

Make sure each PILOTINO WiFi™ PCB and antenna are connected to a power source (5 Vdc).

Properly connect each PILOTINO WiFi™ PCB to a DMX Driver utilizing the DMX IN/OUT connectors.

Power on the PILOTINO WiFi™ PCB once proper wiring connections are done to eliminate short circuiting the boards.

Connect each PILOTINO WiFi™ PCB to the same router by a WPS procedure (for more details see chapter 8.1).

Also connect the smartphone to the router and use any Art-Net iOS or Android App to drive each DMX device.

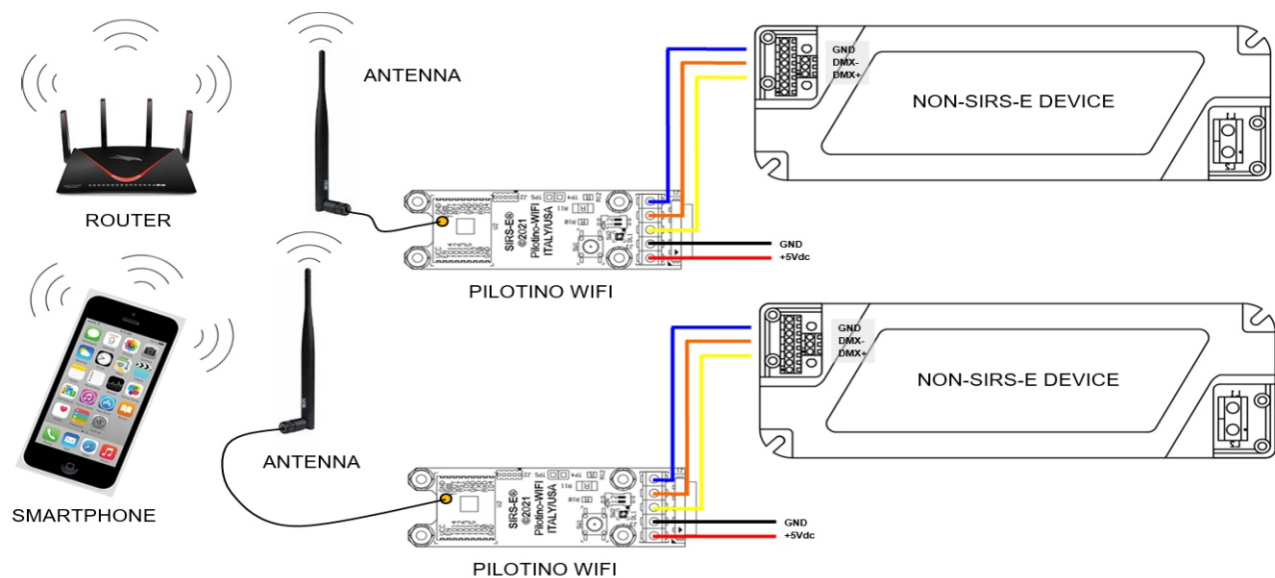

## 6.3 Stand Alone Mode Installation (cont.)

### 6.3.4 Daisy Chain (Station)

Make sure the PILOTINO WiFi™ PCB and antenna are connected to a power source (5 Vdc). Connect the DMX IN/OUT wires to each of the DMX Drivers boards in a sequence, similar to a daisy flower ring, to each corresponding connector.

Power on the PILOTINO WiFi™ PCB once proper wiring connections are done to eliminate short circuiting the boards or controllers.

Connect each PILOTINO WiFi™ PCB to the same router by WPS procedure (for more details see chapter 8.1)

Also connect the smartphone to the router and use any Art-Net iOS or Android App to drive each DMX device.

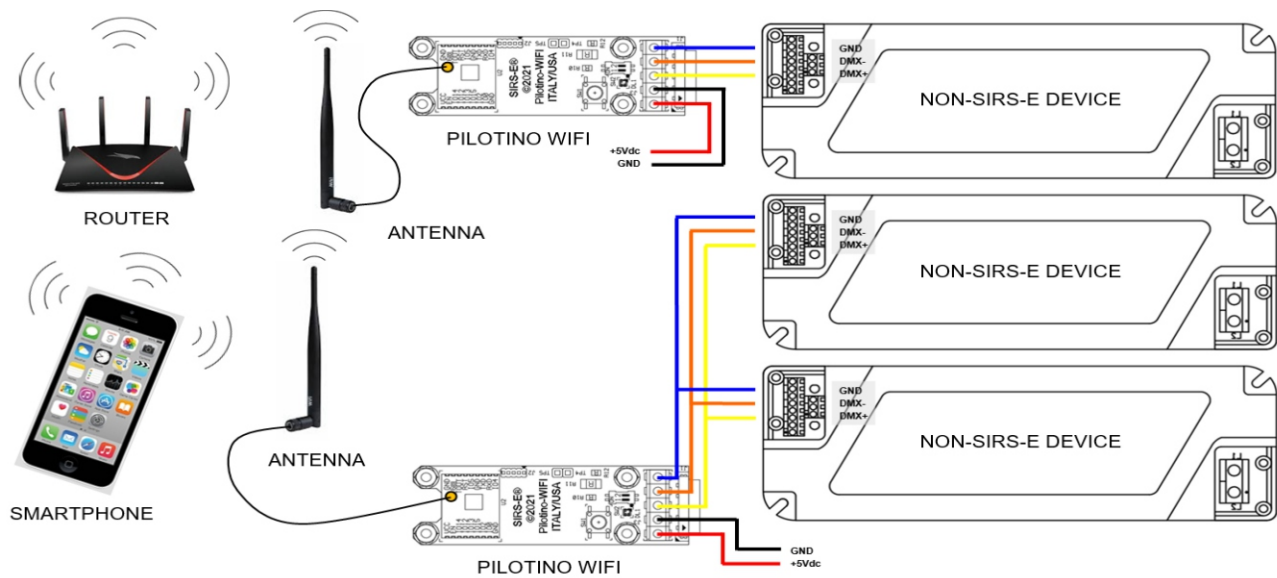



## 7. Wi-Fi - Access Point Mode

The Access Point (default mode) is the PILOTINO WiFi™ PCB acting as its own network. A cyan indicator LED turns steady on the PILOTINO WiFi™ PCB. This allows for a complete wireless solution for a smartphone to act as a DMX controller.

### 7.1 Network Connection

After turning on the power to the PILOTINO WiFi™ PCB, a green indicator LED turns steady.

After a few seconds, the indicator LED turns from green to cyan; the PILOTINO™'s internal WiFi network is now ready to pair.

With the smartphone device, go to the “Settings -> WiFi/Network -> PilotWiFi\_####”, where #### is a random sequence of four numbers.

When first prompted for a password, type PilotWiFi\_0000

### 7.2 Art-Net App Connection

Art-Net App works on any compatible IOS or Android

When connecting the Art-Net App, make sure that the device being used is connected to the same WiFi network that the PILOTINO WiFi™ PCB is broadcasting

After setting up the App on the smartphone device, a cyan indicator LED on the PILOTINO WiFi™ PCB will blink slowly  
Art-Net signal present!



## 8. Wi-Fi - Station Mode

The Station mode is when the PILOTINO WiFi™ PCB connects to a near by wireless internet router. A blue indicator LED on the PILOTINO WiFi™ PCB turns steady. This allows for a complete wireless solution for a smartphone to act as a DMX controller. With the Station Mode, the router can connect to multiple PILOTINO WiFi™ PCB with a combination of basic connection and daisy chain connections. Very user friendly when working on different projects from residential to a business, or personal use.

### 8.1 Network Connection (WPS)

After turning on the power to the PILOTINO WiFi™ PCB, a green indicator LED turns steady.

After a few seconds, the indicator LED turns from green to cyan; the PILOTINO™'s internal WiFi network is ready to pair.

On a near by wireless router, press the WPS button to initialize scanning for new devices.

Locate the pairing button, on the PILOTINO WiFi™ PCB, then press and hold the button until the LED changes color, from cyan to white.

A steady blue indicator LED is shown on the PILOTINO WiFi™ PCB representing a successful connection with a wireless router.

A slow flashing white indicator LED is shown on the PILOTINO WiFi™ PCB representing a failed connection with a wireless router. In this case, repeat the WPS procedure.

Perform the same operation for all PILOTINO WiFi™ PCB

## 8.2 IP Address

The IP addresses are an identifier assigned from the router and are required for connecting devices to access the network.

On a computer or smartphone device, access the Network & Internet settings and locate the PILOTINO WiFi™ PCB IP settings in the properties section to correctly set the Art-Net App.

Note: PILOTINO WiFi™ PCB support only a DHCP protocol.

## 8.3 Art-Net App Connection

Art-Net App works on any compatible IOS or Android

Configure the WiFi settings and connect the smartphone device to the router in which will be connected on the same network as the PILOTINO WiFi™ PCB.

Launch an application on the smartphone device that has configuration with Art-Net

After setting up the App on the smartphone device, a blue indicator LED on the PILOTINO WiFi™ PCB will blink slowly:

Art-Net signal present!

## 9. Default Setting

To return the PILOTINO WiFi™ PCB to the default settings, press and hold the pairing button, for about 10 seconds, until the indicator LED turns green and has blinked once.

The indicator LED will turn cyan after a few seconds to indicate the PILOTINO WiFi™ PCB is acting as an access point

## 10. Mode LED Indicator

- Green Led Static: Power ON
- Cyan LED static: PILOTINO WiFi™ PCB working with the internal network
- Cyan LED slow blinking: Art-Net or sCAN signal present
- Blue LED static: Module connected to an external WiFi network
- Blue LED slow blinking: Art-Net or sACN signal present
- Blue LED fast blinking: Module disconnected from the external WiFi network
- White LED static: WPS connection
- White LED slow blinking: WPS connection failed
- Yellow LED: DMX signal present on J1 and J3 connector

## 11. Hardware and Accessories

The expansion modules to equip the PILOTINO™ PCB with onboard WiFi capabilities can be instantly converted into an ArtNet node receiving unit. The PILOTINO WiFi™ PCB has an ANT pin to connect a receiving Antenna opposite from the IO socket.

### Key Features:

- RP-TNC external antenna connector
- 2dBi Omni Antenna, TimoTwo
- OEM Coax cable IPEX to RP-TNC, 15 cm
- 50 ohm at 2.45 Ghz



3307 West St.  
 Rosenberg , Texas 77471  
 Phone: 281-324-0908  
[www.sirs-e.com](http://www.sirs-e.com)

# Confirmation Letter



**UL CUSTOMER**

ALBA ELETTRONICA SRL  
Via L Da Vinci 3  
Mogliano Veneto, 31021 Italy

**UL CUSTOMER FILE #**

E203656

**CATEGORY**

Wiring, Printed - Component | ZPMV2

August 4, 2021

As of the above date, UL LLC confirms that ALBA ELETTRONICA SRL is the party associated with UL File # E203656 that appears in the UL Product iQ platform. Public information contained in UL File # E203656 can be viewed using the following link:

<https://iq.ulprospector.com/en/profile?e=202734>

The appearance of a company's name or a specific product/component designation in the UL Product iQ platform does not in itself mean that product or component so specified or identified is subject to UL's Surveillance Program.

The manufacturer's products are not covered under UL's Surveillance Program unless they bear the authorized UL Mark. Therefore, only those products bearing the appropriate authorized UL Mark or UL Recognized Component Mark, the authorized company name, tradename, trademark and product designation shall be considered as being covered by UL's Listing, Classification, or Recognition Service.

If you have questions regarding this letter, please contact the UL Customer Experience Center at [cec@ul.com](mailto:cec@ul.com).

Sincerely,

Leadership & Governance Team  
UL Product iQ

UL LLC

333 Pfingsten Road, Northbrook, IL 60062-2096 USA

T: 847.272.8800 / F: 847.272.8129 / W: [ul.com](http://ul.com)