

+SWISSON

XSW
DMX Splitter / Booster,
Wireless DMX Transmitter &
Wireless DMX Receiver

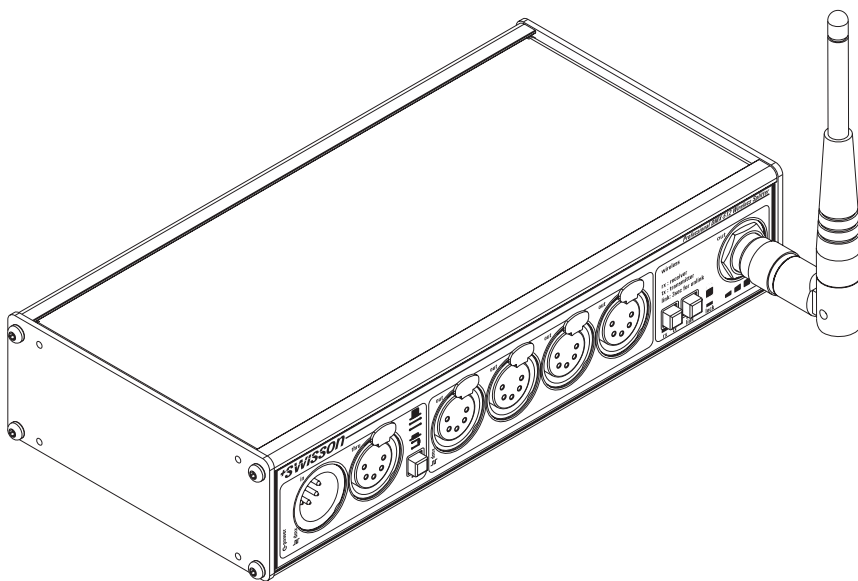

USER MANUAL

BEDIENUNGS ANLEITUNG



+SWISSON

English

E

Deutsch

D**Revisions History**

Revision	Description	Date
1	First Draft	24.04.2012
2	Minor Corrections	24.05.2012

XSW

E

DMX Splitter, Wireless DMX Transmitter & Wireless DMX Receiver

Introduction

The XSW series Wireless DMX splitter/boosters from SWISSON can be easily and economically integrated into any lighting system where you wish to transmit DMX signal wireless. The XSW acts in the same time as DMX splitter and DMX booster.

The XSW can be used as DMX splitter, DMX wireless transmitter or as DMX wireless receiver.

The XSW can be used as a simple wireless link connecting a transmitter to one or more receivers.

All inputs and output ports on the XSW are optically isolated. A strong power supply allows a reliable operation in a wide voltage range. Multiple XSW devices are available; with altering housings and connector types.

Applications

- Concert Lighting
- Live Events
- Multimedia Shows
- Theater
- TV Sets
- Theme Parks

Typical Application

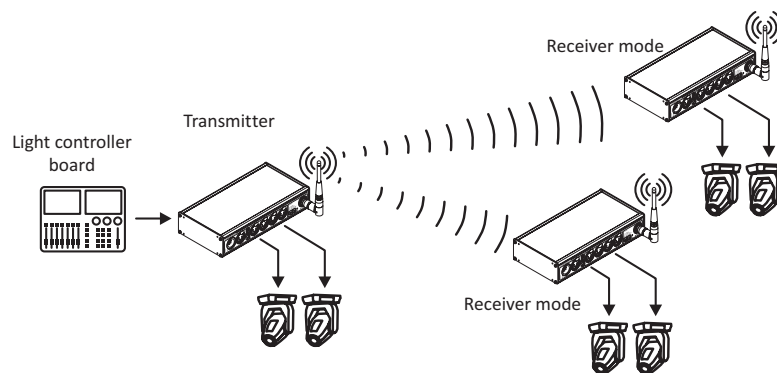

Unpacking

The XSW is packaged in a cardboard box. The following items are included:

- The device
- This user manual
- 1 antenna (2 antennas for double rack versions)

Safety Information

Consider the following notes absolutely when you set up, connect and use the XSW.

E

This product is not for household use. Read this manual before operating the device, follow the safety precautions and observe all warnings in this manual. Use this device only in accordance with local laws and regulations.

Safety precautions

- Disconnect the device from AC power before removing any cover or part, including fuse and when not in use.
- Ensure that the device is electrically connected to ground (earth).
- Use only a source of AC power that complies with local building and electrical codes and has both overload and ground-fault (earth fault) protection.
- Connect the Devices to AC power using the supplied power cable.
- Before using the device, check that the power distribution equipment and cables are in perfect condition and rated for the current required of all connected devices.
- Isolate the device from power immediately if the power cable or power plug in any way damaged, defective or wet, or if they show signs of overheating.
- Do not expose the device to rain or moisture.
- Do not operate the device if any cover or component is missing damaged or deformed.
- Refer any service operation not described in this manual to Swisson.
- Provide unrestricted airflow around the device
- Do not operate the device if the ambient temperature exceeds 55°C (131°F)
- Do not modify the device in any way not described in this manual or install other than genuine Swisson parts.
- Do not attempt to bypass fuse. Replace defective fuse with one of the specified type and rating only.
- When suspending the device, ensure that the supporting structure and all hardware used can hold at least 10 times the weight of all devices suspended from them.
- Install as described in this manual a secondary attachment such as a safety cable that is approved by an official body such as TÜV as a safety attachment for the total weight it secures. The safety cable must comply with EN 60598-2-17 Section 17.6.6 and be capable of bearing a static suspended load 10 times the weight of the device.
- Check all external covers and rigging hardware are securely fastened.
- Block access below the work from a stable platform whenever installing, servicing or moving an overhead device.
- Do not use the device in areas where it is exposed to direct sunlight.
- Do not use the device in areas that are considered to be 'highly combustible'.

Mains Connection

Two different mains connections are available:

E The US versions are delivered by Swisson with a "Edison Plug" (NEMA-5-15). These models has a "-US" suffix

The International versions are delivered without any plug.
Swisson distributors or dealers may deliver the devices with a country specific plug.

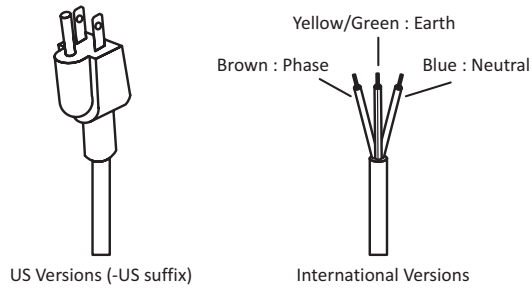

	Wire (US System)	Wire (EU System)	Symbol
Live	black	brown	L
Neutral	white	blue	N
Ground (Earth)	green	yellow/green	⏏ or ⏚



Consult a qualified electrician if you have any doubts about proper installation.

The socket where the device is plugged in must be close to the device and easily accessible.

XSW Block Diagram

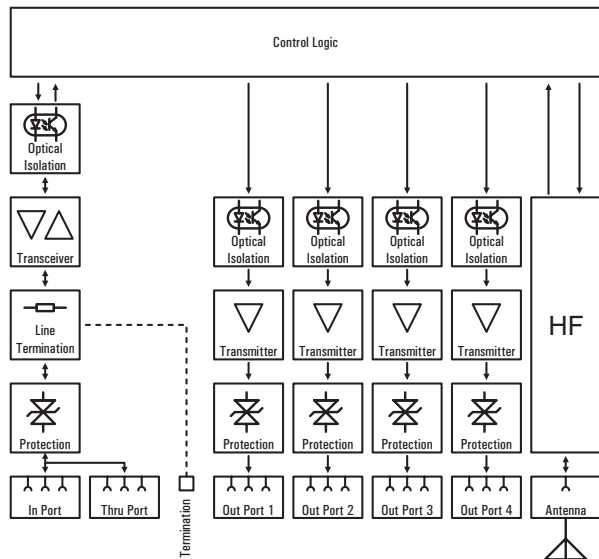

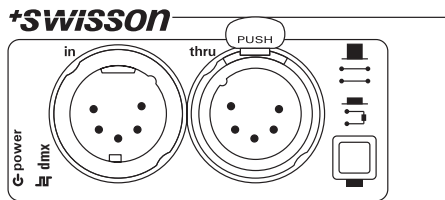

Input Section



E

- 

The Power LED shows if the device is powered when the power supply unit of the XSW is working
- 

A green LED shows if a DMX signal is available at the input port. A red LED shows if the received signal is faulty.
- 

The XSW has a built in line termination. This can be activated by pressing the termination button. A LED shows if the termination is activated.

Input and Thru Port

The Thru port is hardwired with the INPUT port and allows to daisy-chain the devices even when the XSR is not powered. On XSW models with 5-Pin XLR connector, the pins 4 and 5 are also looped thru to the Thru port. On all other models pin 4 & 5 are not available.

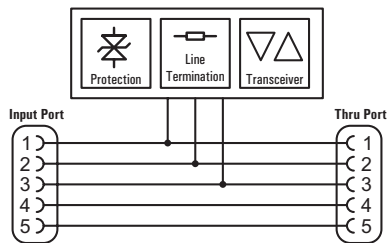

Line Termination

All XSW models have a built-in line termination. The termination is activated by pressing the termination button.

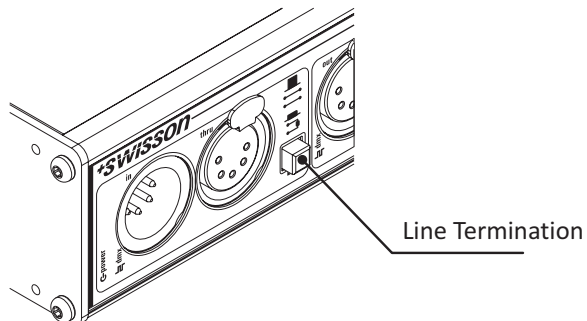

Output Ports

E

The output section

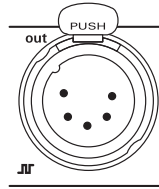

Each output port is individually optically isolated, meaning that it is totally isolated from the other output ports and the input selection.

The pins 4&5 on the models with 5-Pin XLR connectors are not connected.

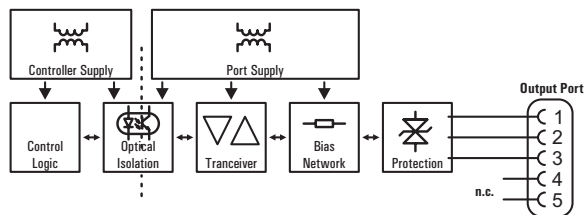

- JIR** The signal LED of the output ports show if a valid signal is transmitted. In Splitter and Wireless Transmitter mode it depends of the signal of the DMX input port. In Wireless Receiver mode it depends of the DMX received from the wireless unit.

Wireless Port

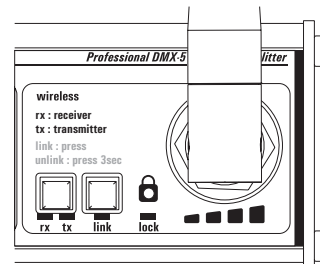

The wireless port can be configured as transmitter or receiver. It can also be turned off to use the XSW as a DMX splitter only.

- rx tx Splitter Only Mode. When both LEDs rx and tx are off, the XSW operates as a Splitter only. The Wireless port is switched off.
- rx tx Receiver Mode. When the rx LED is on, the XSW operates a wireless receiver. The received DMX data is forwarded to the DMX output ports. The DMX input port has no function in this mode.
- rx tx Transmitter Mode. When the tx LED is on, the XSW operates as a wireless transmitter. The DMX data from the DMX input port is transmitted and is also available at the DMX output ports.
- link Link. The link button is used to link a transmitter to one or multiple receivers. The link LED shows if the device is linked.



Lock. A red LED shows if activated. In this case, the mode (rx/tx) and the link buttons are locked. This prevents from an unintended manipulation during operation. The button is only accessible with a tool.

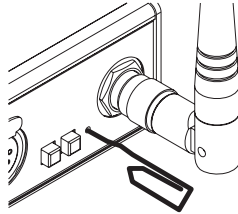

Signal strength. In Receiver mode four green LED shows the signal strength. In Transmitter mode a chaser shows the transmitter is active.



E

Setup a wireless link

To transmit DMX data wireless, a Transmitter and one or more receivers are used. The receiver has to be linked to the Transmitter.

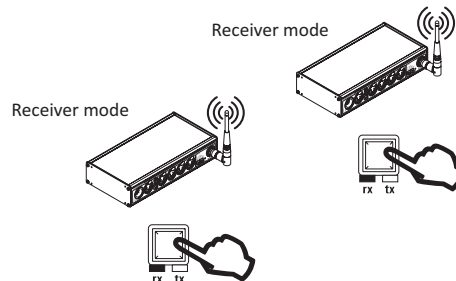
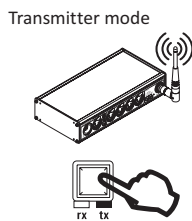

- 1) Press the mode button multiple times until the tx LED is on to select the transmitter mode.

- 2) On receivers: Press the mode button multiple times until the rx LED is on to select the receiver mode.

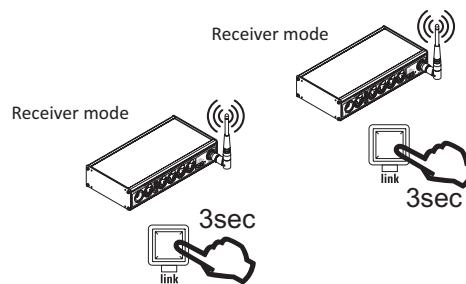
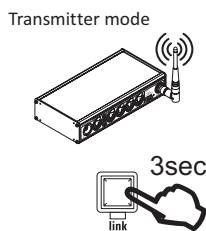

- 3) On transmitter: Press and hold link button for 3 seconds to unlink all devices previously linked to the transmitter.

- 4) On receivers: The receiver might be already linked to another transmitter from a past usage. In this case, the link LED is blinking. Press and hold the link button for 3 seconds to unlink the device.

E

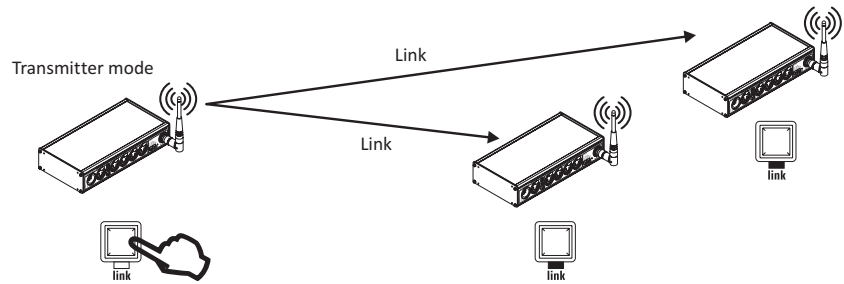

5) On transmitter:
Press link button to link all unlinked receivers in the range of the transmitter

6) On receivers:
The link LED blinks during link operation. The link LED turns permanently on when the link is established and DMX is received from the transmitter.
Short pulses on the link LED shows the link is established but no DMX data is received.

Link LED

The link LED shows different status information depending on the mode.

□ Led off ■ Led on

Transmitter mode



Link in process



Unlink in process



Linked (no DMX)



Linked (DMX ok)

Receiver mode



Unlinked



Linked (no connection to transmitter)



Linked (no DMX)



Linked (DMX ok)

Multiple links

Multiple DMX universe can be used by using multiple links.

1) Configure the units to their corresponding mode. Transmitter or receiver.

E

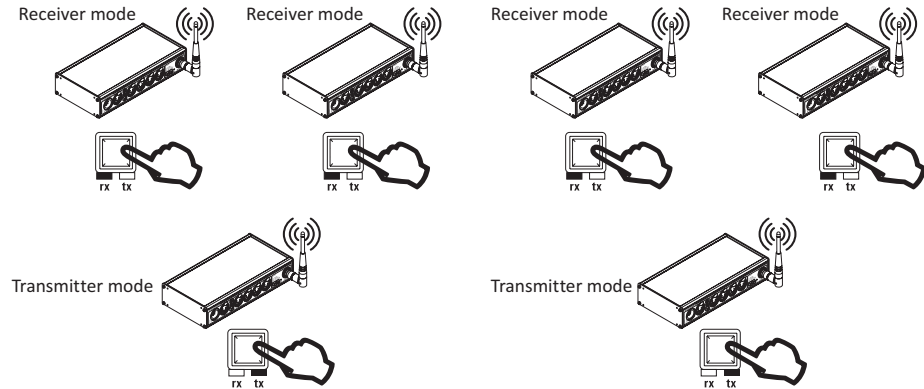

2) Unlink all devices from previous links

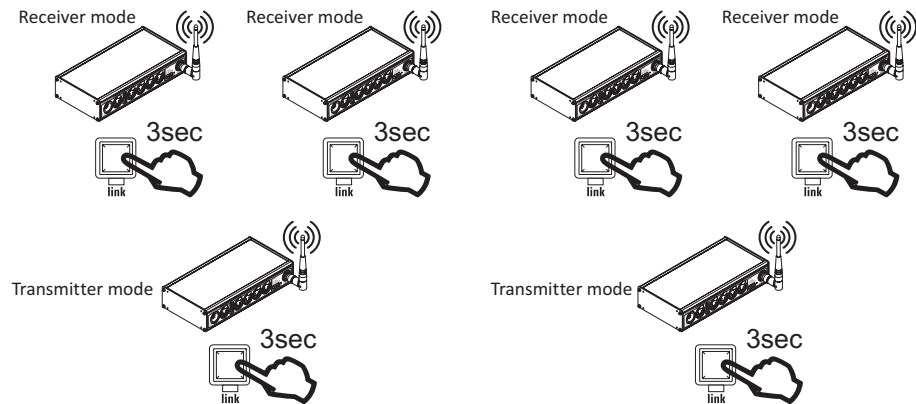

3) Link first universe by pressing the link button on the first transmitter. It will link to all unlinked receivers.

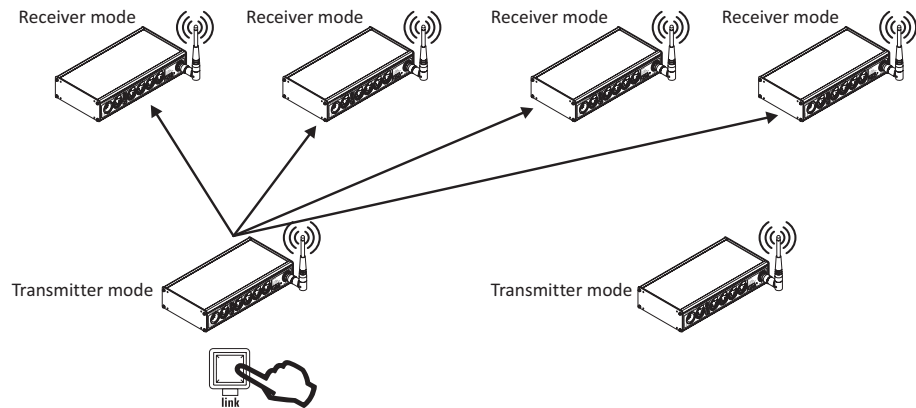

3) Unlink receivers you want to link to the second transmitter.

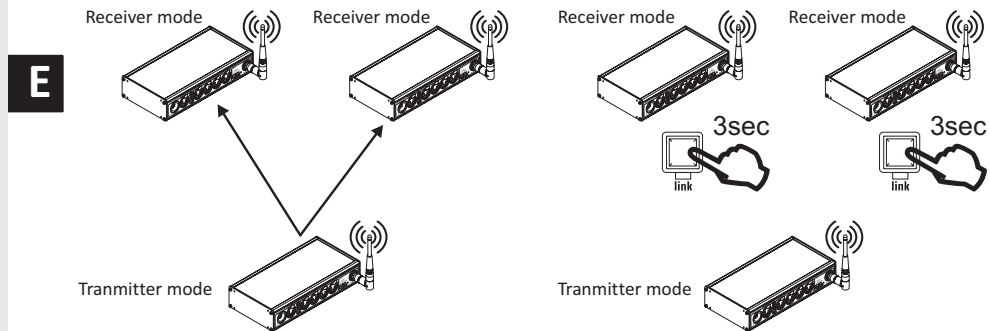

Note: You can switch the receivers you want to link to the secondary transmitter temporarily to Splitter only mode or you can switch them off. This prevent to unlink this receivers from the first transmitter.

4) Link second universe by pressing the link button on the second transmitter. It will link to all unlinked receivers.

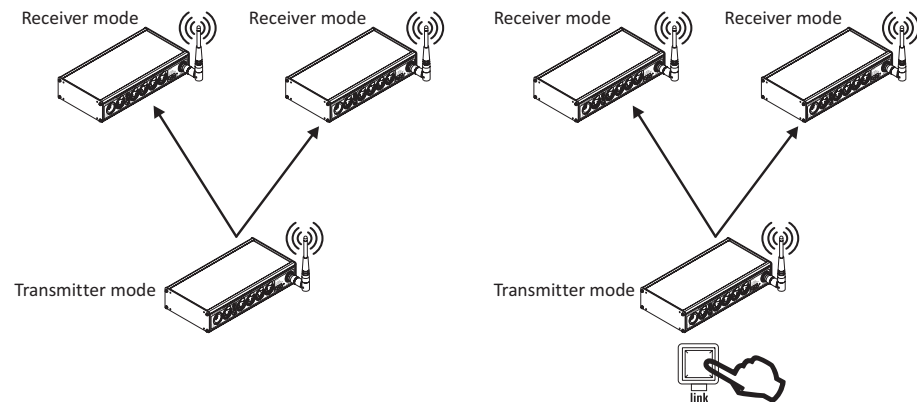

Limits on multiple links

Each transmitter needs bandwidth and there might also be a lot of other devices like WIFI using the same frequency band. It's not recommended to use more than 4-6 transmitters on the same site.

There is no limitation for the numbers of receivers linked to a transmitter.

Position of the Antenna

Try to position the antennas in parallel.

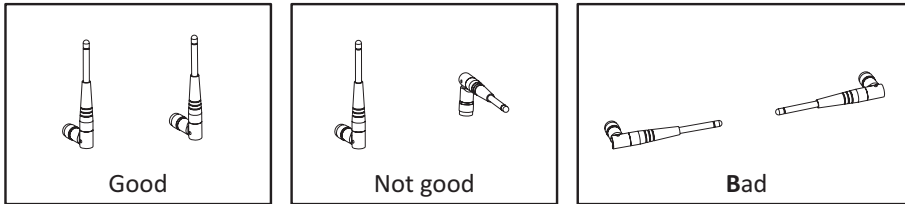

E

Try to position the antenna as high as possible. Avoid to operate the XSW near ground.

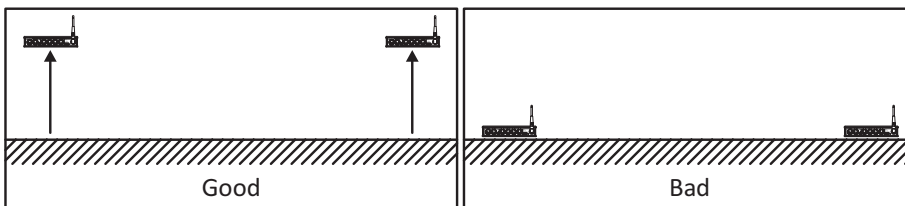

Try to position the antennas as high as possible. A crowd will absorb the signal.

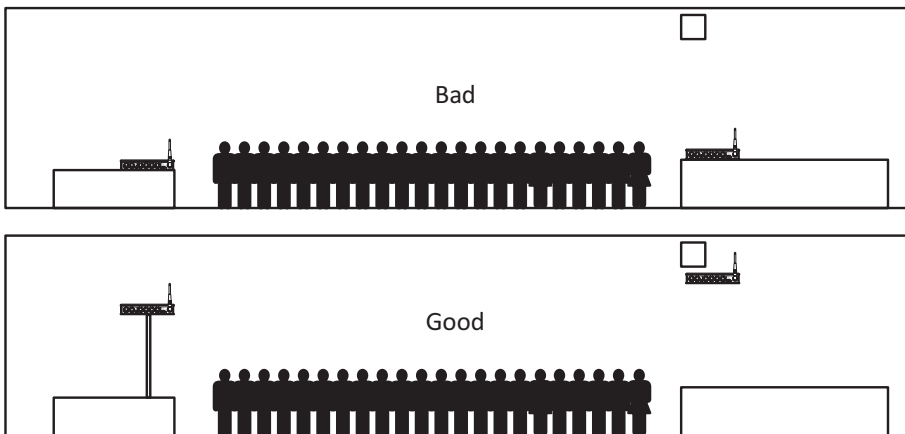

It's better to position the device as high as possible than of using an antenna cable.

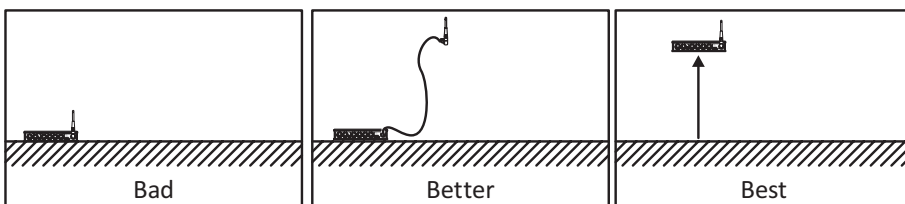

XSW Box Models

E

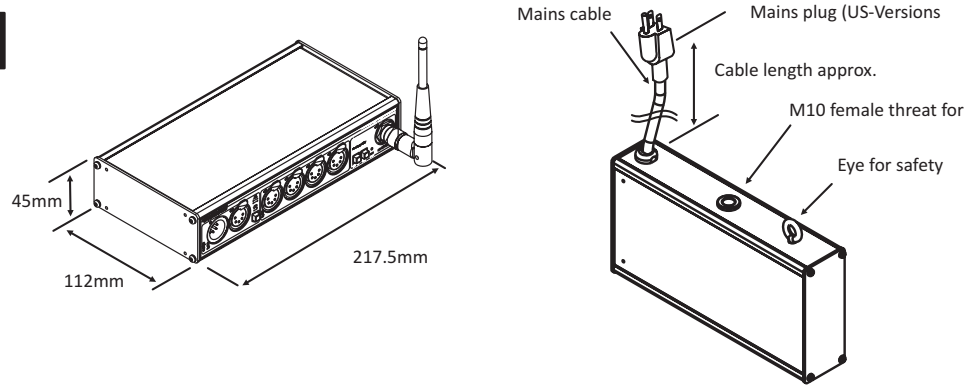

The length of the M10 screw which enters the XSW should not exceed a maximum of 20mm.

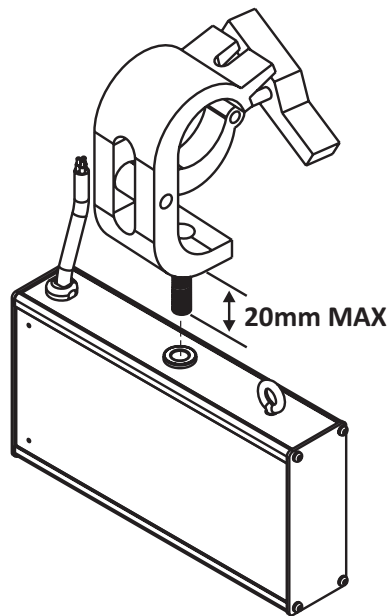

Clamp is not included with the XSW

XSW Single Rack Models

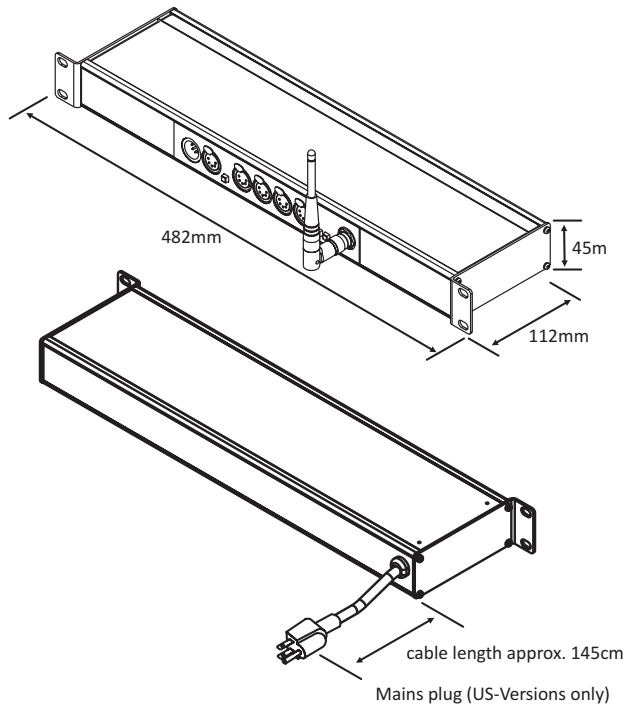

E

XSW Double Rack Models

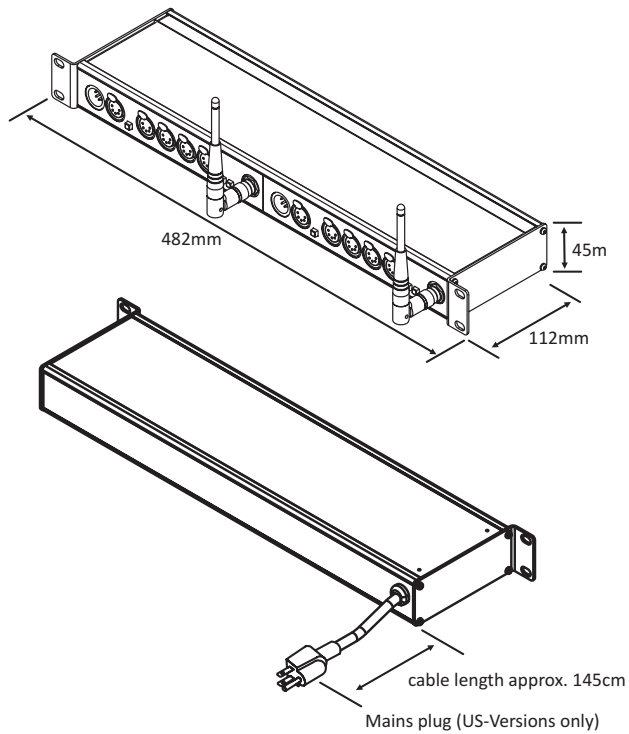

XSW box versions

10 18 10	XSW-3B	3pin XLR
11 18 10	XSW-3B-US	3pin XLR, with NEMA 5-15
10 18 11	XSW-5B	5pin XLR
11 18 11	XSW-5B-US	5pin XLR, with NEMA 5-15

E

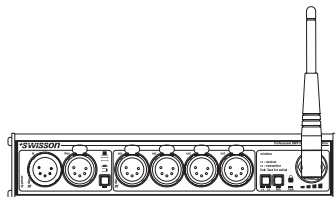

XSW rack versions

10 18 20	XSW-3R	3pin XLR
11 18 20	XSW-3R-US	3pin XLR, with NEMA 5-15
10 18 21	XSW-5R	5pin XLR
11 18 21	XSW-5R-US	5pin XLR, with NEMA 5-15

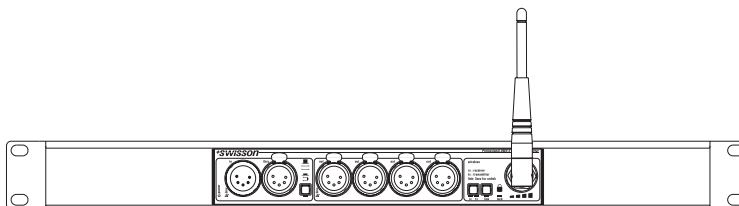

XSW double rack versions

10 18 30	XSW-3R-3R	3pin XLR
11 18 30	XSW-3R-3R-US	3pin XLR, with NEMA 5-15
10 18 31	XSW-5R-5R	5pin XLR
11 18 31	XSW-5R-5R-US	5pin XLR, with NEMA 5-15

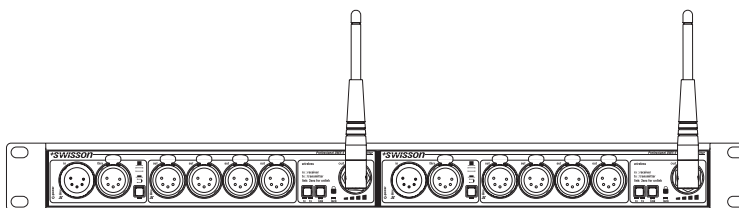

Technical Data

Mains Voltage	100 - 240 [VAC]
Main Frequency	50/60 [Hz]
Current Consumption Single Units	0.3 [A]
Current Consumption Double Units	0.5 [A]
Operating Temperature	0F to 131F (-17°C to 55°C)
Protocol Standard	ANSI E1.11 (DMX-512)

E

No part of this documentation may be reproduced or transmitted in any form or by any means, electronic or mechanical, including photocopying and recording, without the prior written permission of SWISSON AG.

The information in this documentation is supplied without warranty of any kind, either directly or indirectly, and is subject to change without prior written notice. SWISSON its employees or appointed representatives will not be held responsible for any damages to software, hardware, or data, arising as a direct or indirect result of the product(s) mentioned herein.

Issued by

SWISSON AG
Fabrikstrasse 21
CH-3250 Lyss
Switzerland

SWISSON of AMERICA Corp.
2419 East Harbor Blvd. #34
Ventura, CA 93001
U.S.A.