

# XSH

## Hybrid Splitter / Booster

### User manual

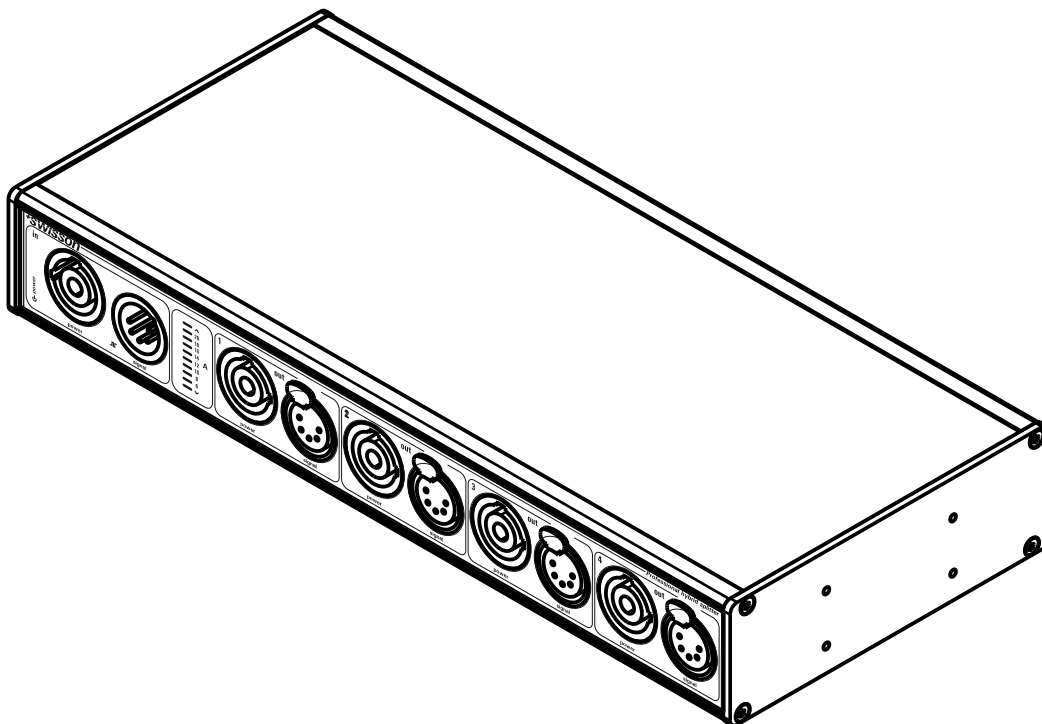

## Introduction

The XSH Hybrid Splitter is a combination of a DMX splitter and a power distribution unit. It may dramatically simplify the installation, especially when PowerCon & DMX hybrid cables are used.

While the XSH-xxD models split and boost only DMX signals, the XSH-xxR models also detect RDM data and use the protocol's bidirectional functionality to report data back to the controller (Lighting board).

All output ports of the XSH are optically isolated. A strong power supply allows a reliable operation in a wide voltage range. The XSH is available with 3-pin or 5-pin XLR connectors.

## Applications

- Concert Lighting
- Live Events
- Multimedia Shows
- Theater
- TV Sets
- Theme Parks
- Architectural Lighting

## Typical Application

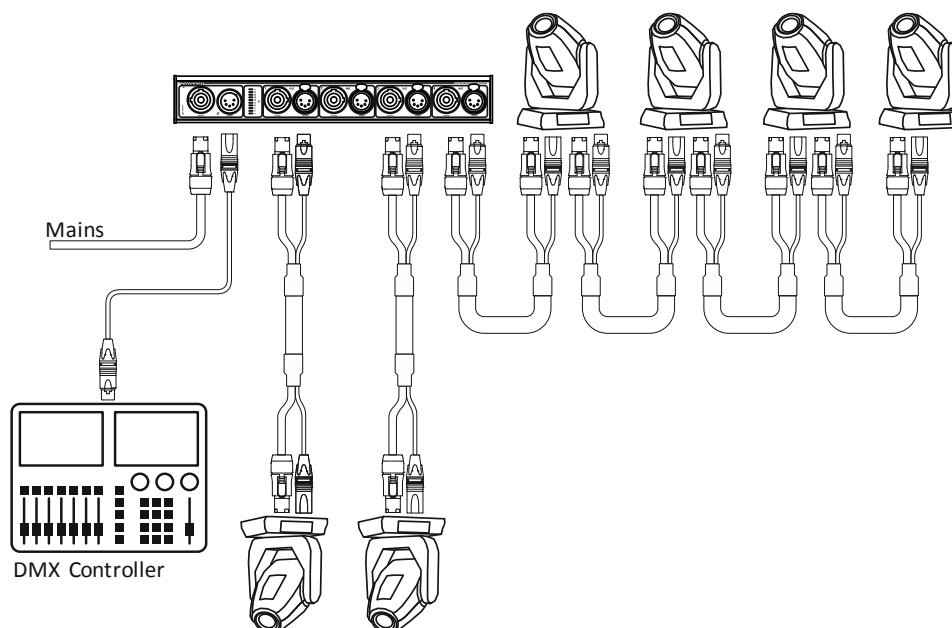

The XSH-xxR works within DMX / RDM environments as well as in pure DMX environments. Therefore, the XSH-xxR is a good solution for those who expect to use RDM in the future. The XSH-xxD on the other hand only works with DMX, while it ignores any RDM data.

## Unpacking

The XSH Hybrid Splitter is packaged in a cardboard box. The following items are included:

- The device.

- This user manual.
- Rack-mount kit (2 brackets and 8 screws) with XSH-xRx versions only.

## Safety Information

**Consider the following notes absolutely when you set up, connect and use the XSH.**

**This product is not for household use. Read this manual before operating the device, follow the safety precautions and observe all warnings in this manual.**

**Use this device only in accordance with local laws and regulations.**

## Safety Precautions

- **Disconnect the device from AC power before removing any cover or part, including any fuse and when not in use.**
- **Ensure that the device is electrically connected to ground (earth).**
- **Use only a source of AC power that complies with local building and electrical codes and has both overload and ground-fault (earth fault) protection.**
- **Before using the device, check that the power distribution equipment and cables are in perfect condition and rated for the current required of all connected devices.**
- **Isolate the device from power immediately if the power cable or the power plug is in any way damaged, defective or wet, or if they show signs of overheating.**
- **Do not expose the device to rain or moisture.**
- **Do not operate the device if any cover or component is missing, damaged or deformed.**
- **Refer any service operation not described in this manual to SWISSON.**
- **Provide unrestricted airflow around the device.**
- **Do not operate the device if the ambient temperature exceeds 55°C (131°F).**
- **Do not modify the device in any way not described in this manual or install other than genuine SWISSON parts.**
- **Do not attempt to bypass any fuse. Replace any defective fuse with one of the specified type and rating only.**
- **When suspending the device, ensure that the supporting structure and all hardware used can hold at least 10 times the weight of all devices suspended from them.**
- **When suspending the device, install a secondary attachment such as a safety cable that is approved by an official body such as TÜV as a safety attachment for the total weight it**

secures. The safety cable must comply with EN 60598-2-17 Section 17.6.6 and be capable of bearing a static suspended load 10 times the weight of the device.

- Make sure that any external cover and rigging hardware is securely fastened.
- Block access below the work area whenever installing, servicing or moving an overhead device.
- Do not use the device in areas where it is exposed to direct sunlight.

## XSH Block Diagram

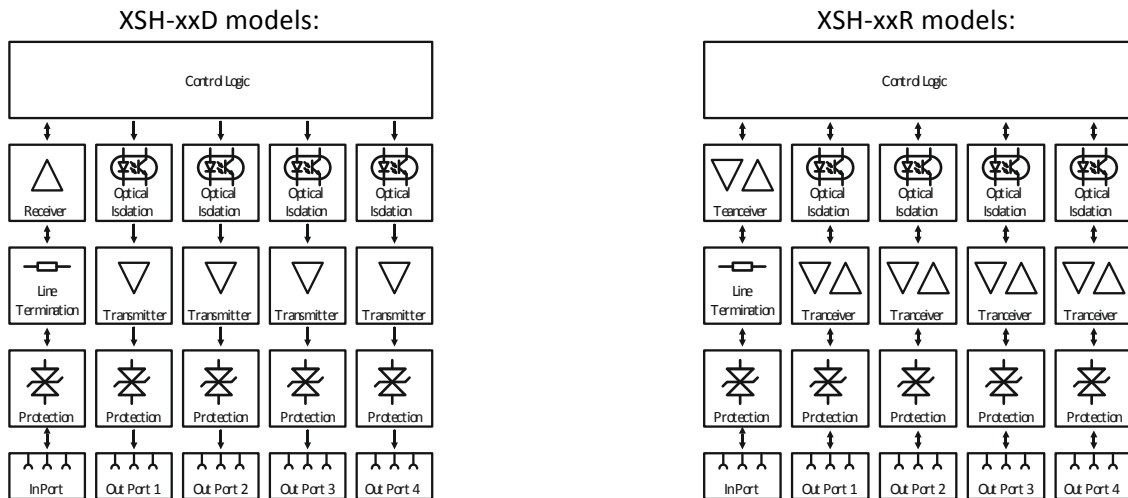

## Device Overview

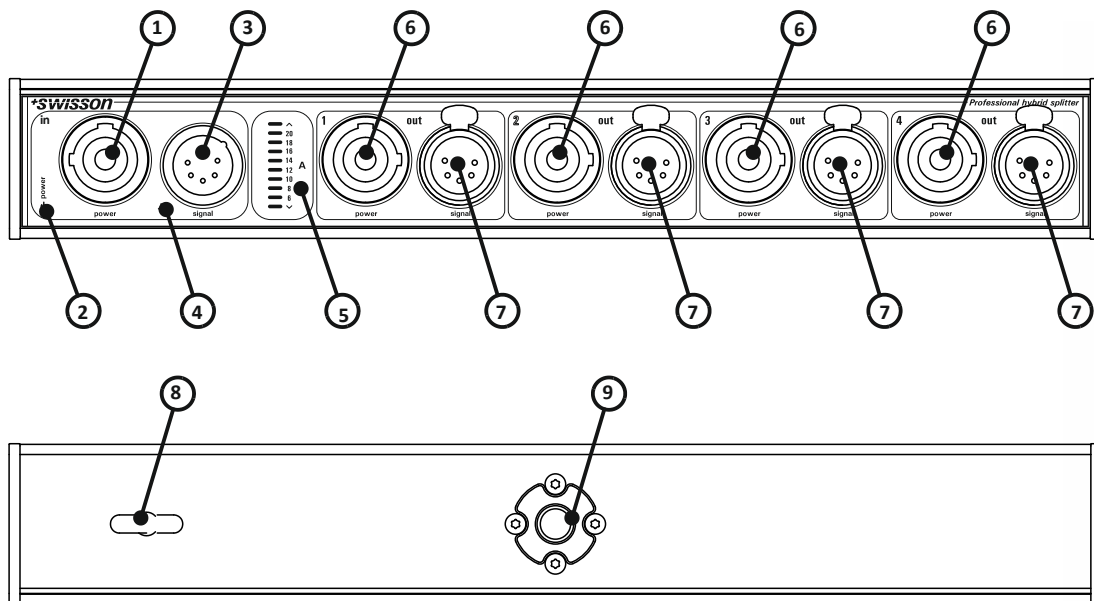

1. Mains power input. See chapter "Mains Connection" on page 6 for more details.
2. Power LED. The Power LED shows if the device powered and if power supply unit of the XSH is working.
3. DMX input.
4. Signal LED. A green LED shows if a signal is available at the input port. A red LED shows if received signal is faulty.
5. Amp display. The bar graph LED shows the total amps drawn though the XSH.
6. Power outlets.
7. DMX outputs.
8. Eye for safety wire.

- M10 & M12 female thread for clamp.

## Mains Connection

The user must supply a suitable power cable. The user must then either hard-wire the power cable to the building's electrical installation, providing an easily accessible power on/off switch close to the device, or install on the power cable a grounding-type (earthed) mains plug that is suitable for the local power outlets, following the power plug manufacturer's instructions. Consult a qualified electrician, if you have any doubts about proper installation.

A blue *Neutrik PowerCon NAC3FCA* cable mount connector must be used to supply power at the XSH hybrid splitter power input socket.

**Warning! For protection from dangerous electric shock, the device must be grounded (earthed). The local AC power source must have both overload and ground-fault (earth fault) protection.**

**Important! Only insert or remove a live Neutrik PowerCon connector to apply or cut power in an emergency, as doing so may cause arcing at the terminals that will damage the connectors.**

## Power Outlets

**Warning! The total current load of all devices connected to AC mains power outlets of the XSH hybrid splitter power must not exceed 19.8 amps.**

- A power cable that meets the requirements specified on safety instructions of this manual must be used to connect the XSH Hybrid Splitter to AC mains power and to connect other devices to the power outlets.
- A light-grey Neutrik PowerCon NAC3FCB cable-mount connector must be used to draw AC mains power from the XSH Hybrid Splitter's power outlets.
- No matter what the AC mains power voltage is, the current draw of all the devices that draw AC mains power from the power outlets of an XSH hybrid splitter must not exceed a total of 19.8 amps.

## DMX Connections

Depending on the version, the XSH is equipped with 5-pin or 3-pin XLRs.

Pin	Connection
1	GND
2	Data -
3	Data +
4	Not connected
5	Not connected

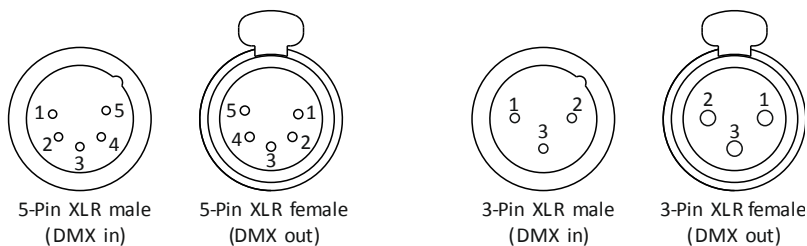

The DMX input is fully isolated and has a built in termination. All outputs are isolated transmitters with a bias network for RDM operation. Each output port is individually optically isolated, meaning that it is totally isolated from the other output ports and from the input section.

## Current Measurement

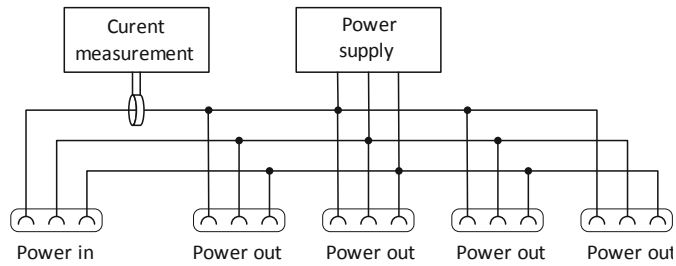
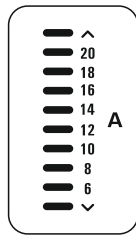

The bar graph LEDs show the total amps drawn by and through the XSH. The lighting down arrow led shows that the load is less than six amps if all other LEDs are turned off.

The lighting up arrow shows that the load exceeds 20A. This is an overload condition! Never run an installation in this condition.

The current sensor value is also reported over RDM (XSH-xxR models only).

Note: The LED bar graph is also used to show the RDM identify. See RDM Protocol (Remote Device Management).

## RDM Protocol (Remote Device Management)

All XSH-xxR models support the RDM protocol. The RDM protocol is not supported on XSH-xxD models. The XSH-xxR forward the RDM messages to all connected devices and send the RDM responses back to the RDM controller. The XSH-xxR acts as a non-proxy inline device. The XSH-xxR itself is a responder to RDM messages and can be discovered on a RDM network.

## Dimensions

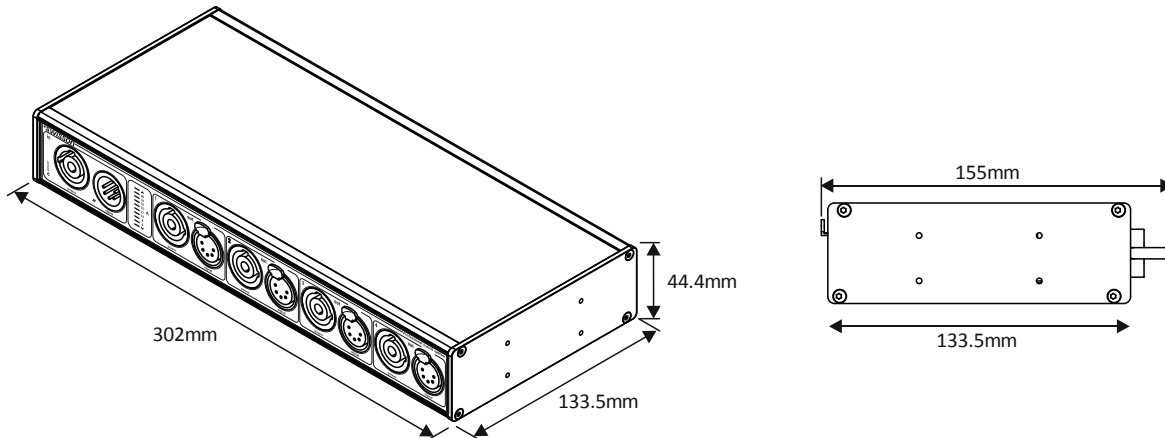

## 19-inch Rack Mount Option

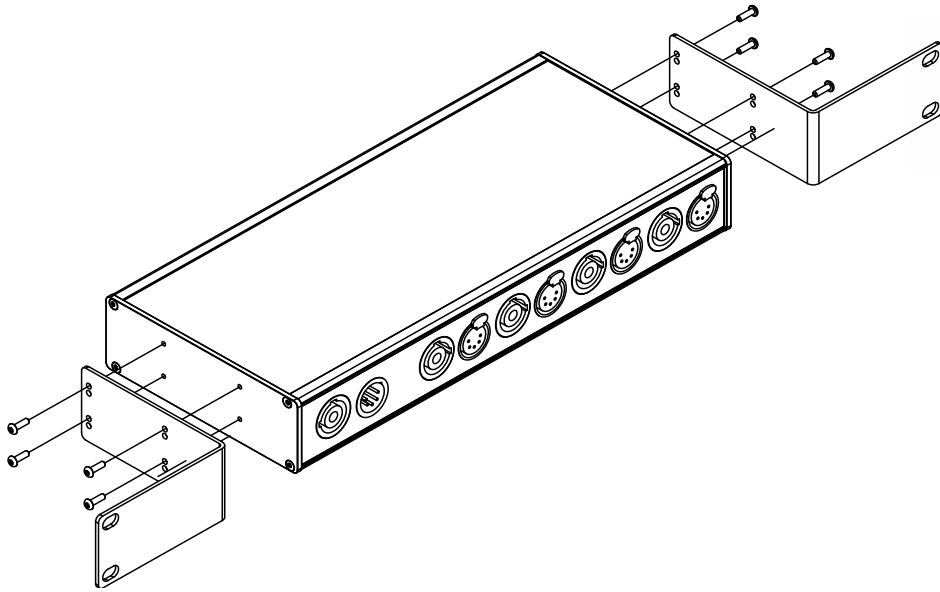

To mount in a rack:

Fasten the L-brackets using the included, thread-forming Torx 10 M3 x 8 screws as shown above.

Note: XSH-xBx models are shipped without L-brackets and screws. XSH-xRx models are shipped with L-brackets and screws. The rack mounting kit (L-brackets and screws) can also be ordered separately.

**Warning! Do not use screws with a thread length of more than 8 mm (0.32 in.) for mounting the brackets onto the XSH.**

## Technical data

Depth .....	133.5 mm (5.3 in)
Width .....	302 mm (11.9 in)
Height .....	44.4 mm (1.7 in)
Weight .....	1.4 kg (3 lb )
Ambient temperature.....	-30°C...55°C (-22°F...137°F)
AC power .....	100 - 240 V nominal, 50/60 Hz
Power supply unit .....	Switch mode, auto-sensing
Typical power consumption.....	4W
DMX .....	ANSI E1.11
RDM .....	ANSI E1.20
Electrical standard signal ports.....	EIA-485

## Ordering information

### DMX-512 Versions

10 13 10	XSH-3BD-1P4	Hybrid Splitter Box, 3-Pin XLR, DMX
10 13 11	XSH-5BD-1P4	Hybrid Splitter Box, 5-Pin XLR, DMX
10 13 20	XSH-3RD-1P4	Hybrid Splitter with rack mount kit, 3-Pin XLR, DMX
10 13 21	XSH-5RD-1P4	Hybrid Splitter with rack mount kit, 3-Pin XLR, DMX

### DMX-512 and RDM Versions

10 13 50	XSH-3BR-1P4	Hybrid Splitter Box, 3-Pin XLR, DMX & RDM
10 13 51	XSH-5BR-1P4	Hybrid Splitter Box, 5-Pin XLR, DMX & RDM
10 13 60	XSH-3RR-1P4	Hybrid Splitter with rack mount kit, 3-Pin XLR, DMX & RDM
10 13 61	XSH-5RR-1P4	Hybrid Splitter with rack mount kit, 5-Pin XLR, DMX & RDM

### Accessories

10 90 75	XAC-RACKM-XSH	Rack mounting kit for hybrid splitter
----------	---------------	---------------------------------------