



The Original DMX-CON4
US Engineered
New generation 4 channel LED driver

4 Channel RGBW LED DMX Controller

Model: DMX-CON4
Control: DMX512-A (Meets USITT DMX512/1990)
Total MAX Output: 5A/Channel @ DC 12V, 2.5A/Channel @ DC 24V, 240W total
Applies to all kinds of LEDs controlled by voltage.

Summary

Thank you for choosing our series of DMX-CON4 Driver. This new revision of the DMX-CON4 DMX driver has a frequency of 5.2 kHz which allows it to be used for video applications with no camera flickering, as well as a total power of 240W. This LED Driver provides you with the freedom to control 4 channels of LED strip, LED modules, and other types of 12-24 V LED lighting. Each channel provides you control from 1-256 levels of intensity. This driver complies with DMX 512/1990 Protocol.

Product Features

- Meets DMX512/1990
- 256-levels of brightness, full-color with driver controls
- 4 output channels, max 5A per channel
- Can achieve asynchronous color changes effects
- Capable of controlling LED light with 1-4 colors
- Freely set the DMX address 1-512
- Modularizing can be matched with different LED modules

Tech-parameters

Decode CH: 1-4
 Signal Input: DMX512-A Digital Signal
 Signal Output: 0~V+(V+ is power supply) max 5A/Channel @ DC 12V output drive
 Power Supply: DC 12V-24V
 Power Dis. : <1W
 Power Output: 12-24 V DC, <240W Total
 Ambient Temp. : -10°C ~ 55°C
 Size: 158 x 47.50 x 22.35 mm (6.22 x 1.87 x 0.88 in)
 Net Weight: 209.79 g (7.4 oz)
 Frequency: 5.2 kHz (Flicker-Free Refresh Rate)

***Note: This model of DMX-CON4 is rated IP40 non waterproof, please keep dry at all times.**

Dimensions

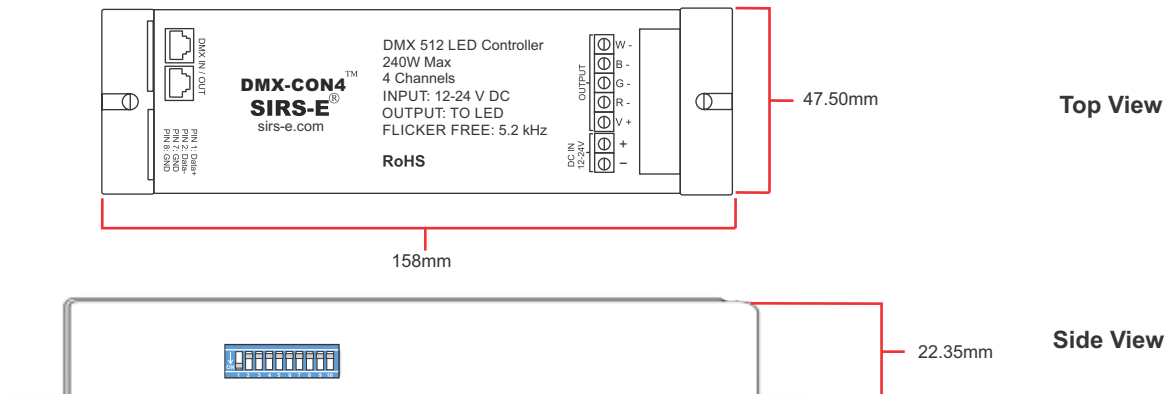

Application Tips

- Place DMX-CON4 in a ventilated area, Do not install in air tight locations.
- DMX-CON4 can be installed on top of a metal plate to aid in the heat sinking process.
- Never exceed the limits in the specifications.
- Do not install where moisture is present.
- Always have LED fixtures as close as possible to the DMX-CON4 to minimize voltage drop due to cable resistance.
- If distance between DMX-CON4 and LED fixture is greater than 3 meters use at least 14 AWG wire.
- For use in Dry or Damp locations only.

Physical Layout

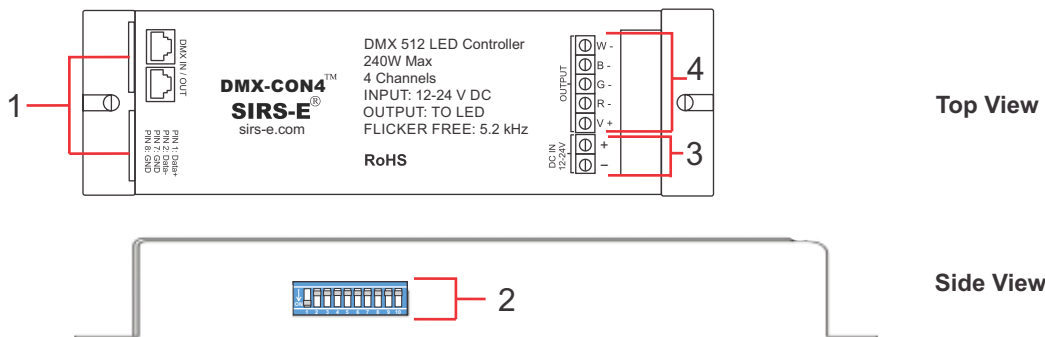

Legend

1. RJ45 ISOLATED DMX IN/OUT
2. DMX DIP SWITCH ADDRESS SELECTOR
3. DC 12 V INPUT
4. OUTPUT CHANNELS 1-4 AND COMMON V+

DMX Pinout

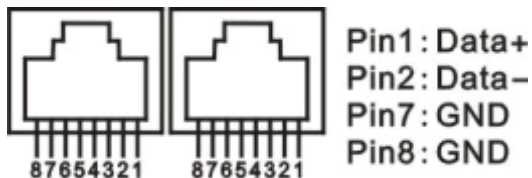

DMX pinout consists of 3 pins in most cases.
Pin 2 from the DMX XLR is correspondant to pin 1 in the RJ-45 connector as Data +.
Pin 3 from the DMX XLR is correspondant to pin 2 in the RJ-45 connector as Data -.
Pin 1 from the DMX XLR is correspondant to pin 7 and 8 in the RJ-45 Connector as Ground.

DIP Switch Addressing Samples

The DMX-CON4 is equipped with a DIP switch system that allows you to address your unit to the desired address using a binary code method. Binary code can be tricky at first to figure out, but once it's been mastered, it becomes a really efficient way to address your units.

DIP Switch Value Chart

DIP	1	2	3	4	5	6	7	8	9
Value	1	2	4	8	16	32	64	128	256

The chart above can be used to determine the value of each DIP switch. Binary code works by adding DIP switch values to achieve the desired address.

Test Mode

The DMX-CON4 has a Test Mode that does not require a DMX signal to test your LED application. To enter Test Mode just turn all the DIP switches to OFF. Once in Test Mode, the LEDs should turn all colors ON.

Addressing Samples

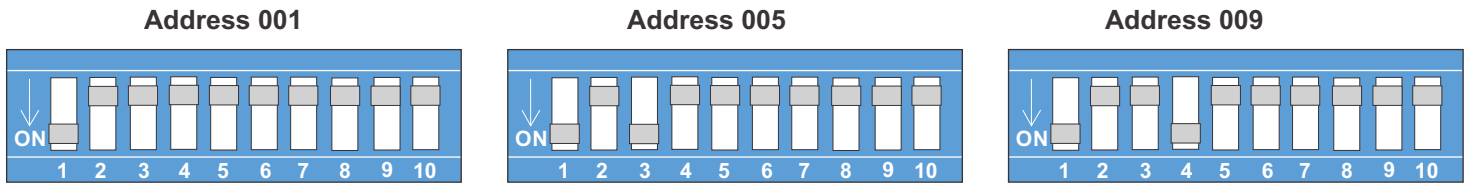

The samples above are intended to help you understand the way binary code works, If you are still having issues addressing your units, you can use this DIP switch calculator found online under this link:

<http://www.sabretechnology.co.uk/calc.asp?dmx>

You can also download the DMX2DIP iphone app to aid you in the calculating process.

<https://itunes.apple.com/us/app/dmx2dip/id514122166?mt=8>

***Note**

- *We recommend you hire a lincensed electrician for any electrical connection, and or installation.*
- *We reserve the right to make changes without any prior notice.*

Last revised on 10/20/2016